

HMW60N075UF7

N-Channel eMOS UF7 Power MOSFET

600 V, 42 A, 75 mΩ

Description

The 600V eMOS UF7 series has ultra-fast body diode performance using E7 technology. eMOS UF7 is Power Master Semiconductor's advanced fast recovery Super Junction MOSFET family by utilizing charge balance technology for excellent body diode performance, low on-resistance and reduced gate charge. It combines the benefits of a fast switching performance with ease of usage and robustness. Additionally, we offer low reverse recovery time (trr) and reverse recovery charge (Qrr) for the bridge structure topology, especially for resonant converters (LLC, PSFB, etc.).

Applications

- Soft Switching Topologies
- Telecom and Server Power Supplies
- EV Charger and Industrial Power Supplies

Features

| $BV_{DSS} @ T_{J,max}$ | I_D | $R_{DS(on),max}$ | $Q_{g,typ}$ |
|------------------------|-------|------------------|-------------|
| 650 V | 42 A | 75 mΩ | 76 nC |

- Reduced Switching & Conduction Losses
- Fast Recovery Body-Diode
- Lower Gate Resistance
- 100% Avalanche Tested
- Pb-free and RoHS Compliant

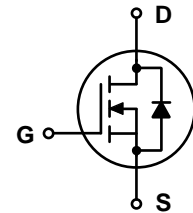
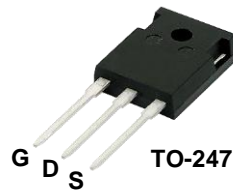

Absolute Maximum Ratings ($T_C = 25^\circ\text{C}$ unless otherwise noted)

| Symbol | Parameter | Value | Unit |
|----------------|---|--|------------------|
| V_{DSS} | Drain to Source Voltage | 600 | V |
| V_{GSS} | Gate to Source Voltage | ±30 | V |
| I_D | Drain Current | Continuous ($T_C = 25^\circ\text{C}$) | 42 |
| | | Continuous ($T_C = 100^\circ\text{C}$) | 26.6 |
| I_{DM} | Drain Current | Pulsed (Note1) | 126 |
| E_{AS} | Single Pulsed Avalanche Energy | (Note2) | 254 |
| I_{AS} | Avalanche Current | (Note2) | 6.3 |
| E_{AR} | Repetitive Avalanche Energy | (Note1) | 3.29 |
| dv/dt | MOSFET dv/dt | 100 | V/ns |
| | Peak Diode Recovery dv/dt | (Note3) | |
| P_D | Power Dissipation | ($T_C = 25^\circ\text{C}$) | 329 |
| | | Derate Above 25°C | 2.63 |
| T_J, T_{STG} | Operating and Storage Temperature Range | -55 to 150 | $^\circ\text{C}$ |
| T_L | Maximum Lead Temperature for Soldering, 1/8" from Case for 10 Seconds | 260 | $^\circ\text{C}$ |

Thermal Characteristics

| Symbol | Parameter | Value | Unit |
|-----------------|---|-------|--------------------|
| $R_{\theta JC}$ | Thermal Resistance, Junction to Case, Max. | 0.38 | $^\circ\text{C/W}$ |
| $R_{\theta JA}$ | Thermal Resistance, Junction to Ambient, Max. | 40 | |

Package Marking and Ordering Information

| Part Number | Top Marking | Package | Packing Method | Quantity |
|--------------|--------------|---------|----------------|----------|
| HMW60N075UF7 | HMW60N075UF7 | TO-247 | Tube | 30 units |

Electrical Characteristics ($T_C = 25^\circ\text{C}$ unless otherwise noted)

| Symbol | Parameter | Test Conditions | Min | Typ | Max | Unit |
|--------|-----------|-----------------|-----|-----|-----|------|
|--------|-----------|-----------------|-----|-----|-----|------|

Off Characteristics

| | | | | | | |
|------------|-----------------------------------|---|-----|----|-----------|---------------|
| BV_{DSS} | Drain to Source Breakdown Voltage | $V_{GS} = 0\text{ V}, I_D = 1\text{ mA}$ | 600 | | | V |
| | | $V_{GS} = 0\text{ V}, I_D = 1\text{ mA}, T_J = 150^\circ\text{C}$ | 650 | | | |
| I_{DSS} | Zero Gate Voltage Drain Current | $V_{DS} = 600\text{ V}, V_{GS} = 0\text{ V}$ | | | 10 | μA |
| | | $V_{DS} = 480\text{ V}, V_{GS} = 0\text{ V}, T_J = 125^\circ\text{C}$ | | 30 | | |
| I_{GSS} | Gate-Source Leakage Current | $V_{GS} = \pm 30\text{ V}, V_{DS} = 0\text{ V}$ | | | ± 100 | nA |

On Characteristics

| | | | | | | |
|--------------|--------------------------------------|---|-----|----|-----|------------|
| $V_{GS(th)}$ | Gate Threshold Voltage | $V_{GS} = V_{DS}, I_D = 2.8\text{ mA}$ | 3.0 | | 5.0 | V |
| $R_{DS(on)}$ | Static Drain to Source On Resistance | $V_{GS} = 10\text{ V}, I_D = 21.5\text{ A}$ | | 64 | 75 | m Ω |

Dynamic Characteristics

| | | | | | | |
|--------------|-----------------------------------|---|--|------|--|----------|
| C_{iss} | Input Capacitance | $V_{DS} = 400\text{ V}, V_{GS} = 0\text{ V},$ $f = 250\text{ kHz}$ | | 3080 | | pF |
| C_{oss} | Output Capacitance | | | 83 | | pF |
| $C_{o(tr)}$ | Time Related Output Capacitance | $V_{DS} = 0\text{ V to } 400\text{ V}, V_{GS} = 0\text{ V}$ | | 817 | | pF |
| $C_{o(er)}$ | Energy Related Output Capacitance | | | 131 | | pF |
| $Q_{g(tot)}$ | Total Gate Charge at 10 V | $V_{DS} = 400\text{ V}, I_D = 21.5\text{ A},$ $V_{GS} = 10\text{ V}$ | | 76 | | nC |
| Q_{gs} | Gate to Source Charge | | | 20 | | nC |
| Q_{gd} | Gate to Drain "Miller" Charge | | | 40 | | nC |
| R_G | Gate Resistance | $f = 1\text{ MHz}$ | | 1 | | Ω |

Switching Characteristics

| | | | | | | |
|--------------|---------------------|---|--|----|--|----|
| $t_{d(on)}$ | Turn-On Delay Time | $V_{DS} = 400\text{ V}, I_D = 21.5\text{ A},$ $V_{GS} = 10\text{ V}, R_G = 4.7\text{ }\Omega$ See Figure 13 | | 20 | | ns |
| t_r | Turn-On Rise Time | | | 12 | | ns |
| $t_{d(off)}$ | Turn-Off Delay Time | | | 61 | | ns |
| t_f | Turn-Off Fall Time | | | 7 | | ns |

Source-Drain Diode Characteristics

| | | | | | | |
|----------|--|--|--|------|-----|---------------|
| I_S | Maximum Continuous Diode Forward Current | | | 42 | | A |
| I_{SM} | Maximum Pulsed Diode Forward Current | | | 126 | | A |
| V_{SD} | Diode Forward Voltage | $V_{GS} = 0\text{ V}, I_{SD} = 21.5\text{ A}$ | | | 1.2 | V |
| t_{rr} | Reverse Recovery Time | $V_{DD} = 400\text{ V}, I_{SD} = 21.5\text{ A},$ $di_F/dt = 100\text{ A}/\mu\text{s}$ | | 134 | | ns |
| Q_{rr} | Reverse Recovery Charge | | | 0.85 | | μC |

※Notes:

1. Repetitive rating: pulse-width limited by maximum junction temperature.
2. $I_{AS} = 6.3\text{ A}, R_G = 25\text{ }\Omega$, starting $T_J = 25^\circ\text{C}$.
3. $I_{SD} \leq 21.5\text{ A}, di/dt \leq 100\text{ A}/\mu\text{s}, V_{DD} \leq 400\text{ V}$, starting $T_J = 25^\circ\text{C}$.

Typical Performance Characteristics

Figure 1. On-Region Characteristics

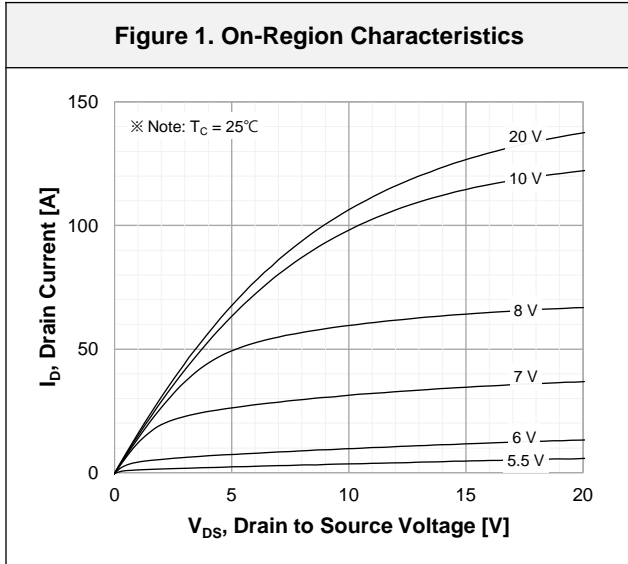

Figure 2. Transfer Characteristics

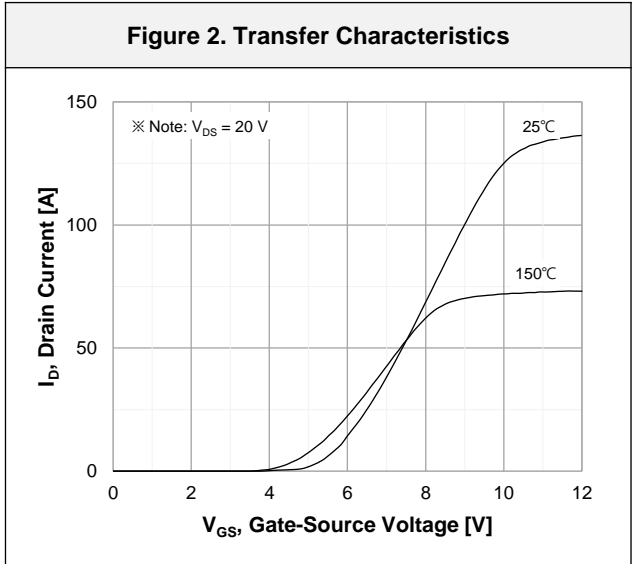

Figure 3. On-Resistance Characteristics vs. Drain Current and Gate Voltage

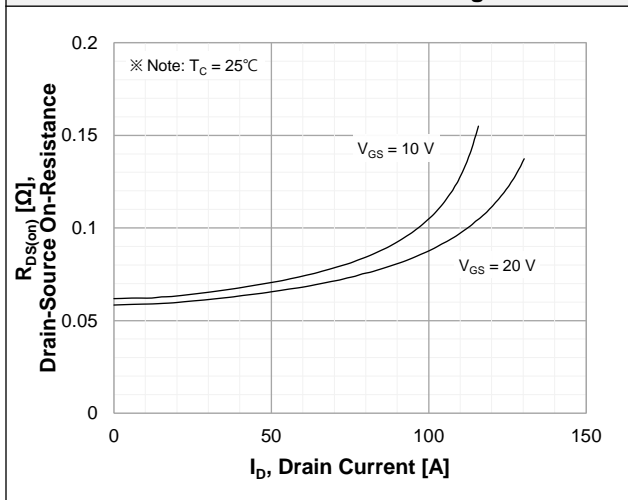

Figure 4. Diode Forward Voltage Characteristics vs. Source-Drain Current and Temperature

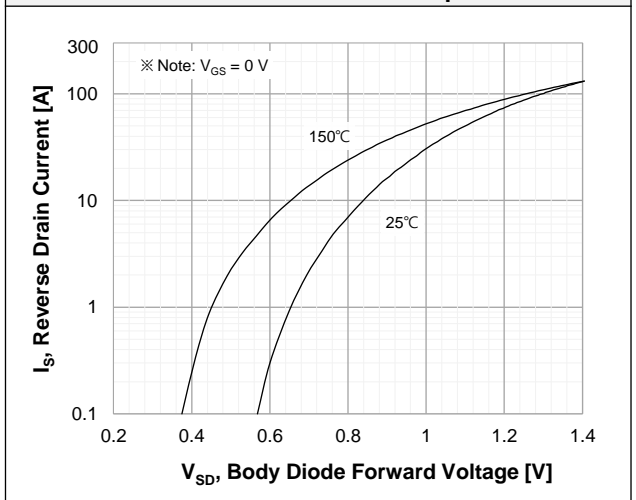

Figure 5. Capacitance Characteristics

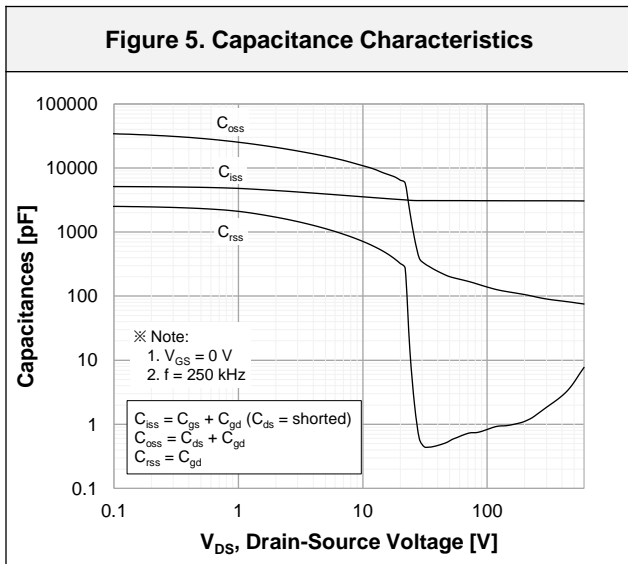
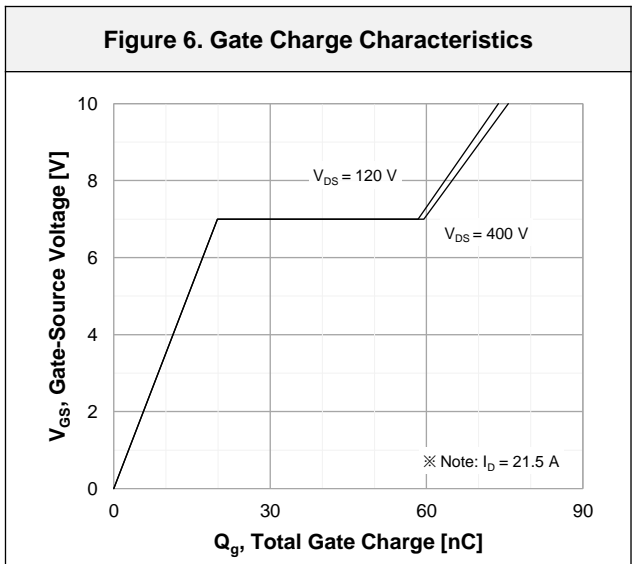

Figure 6. Gate Charge Characteristics



Typical Performance Characteristics

Figure 7. Breakdown Voltage Characteristics vs. Temperature

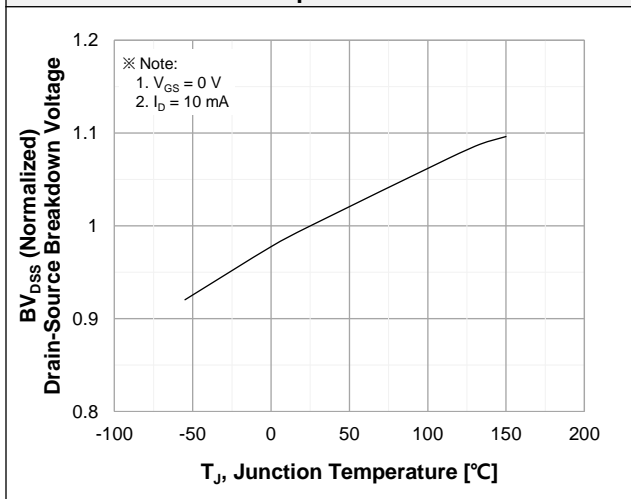

Figure 8. On-Resistance Characteristics vs. Temperature

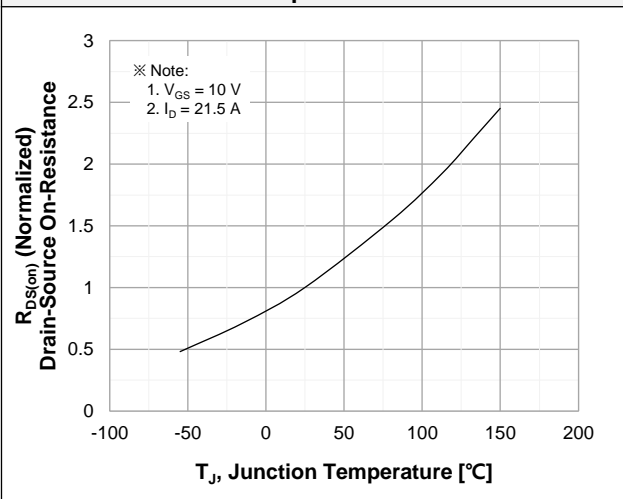

Figure 9. Maximum Safe Operating Area

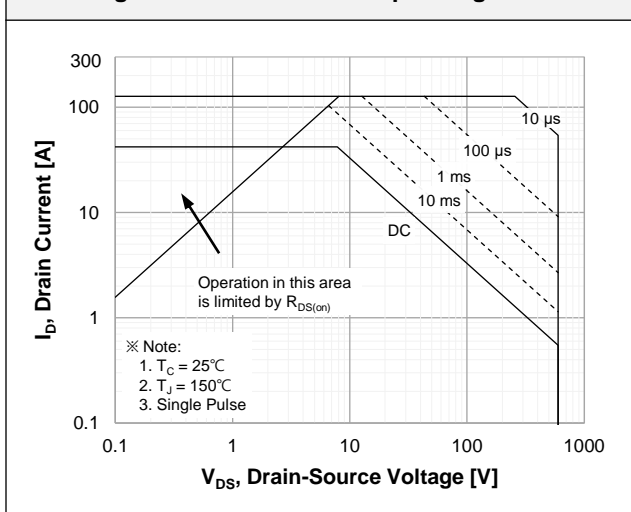

Figure 10. Maximum Drain Current vs. Case Temperature

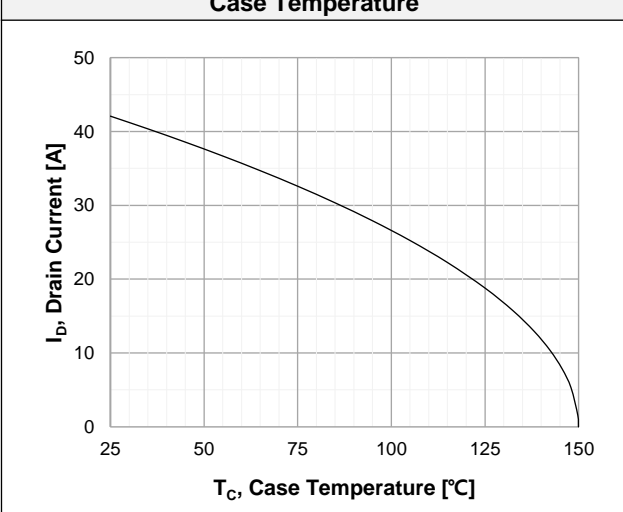

Figure 11. E_oss vs. Drain to Source Voltage

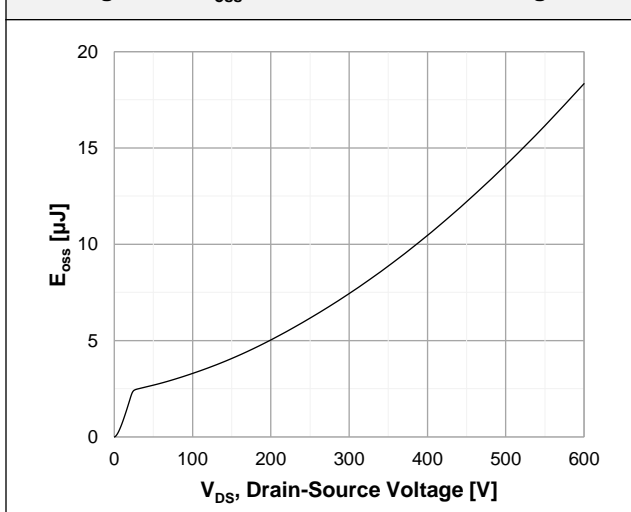
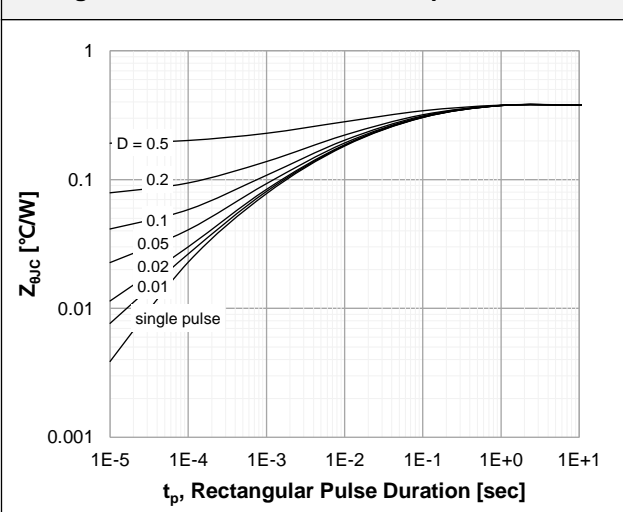

Figure 12. Transient Thermal Response Curve



Test Circuits

Figure 13. Inductive Load Switching Test Circuit and Waveforms

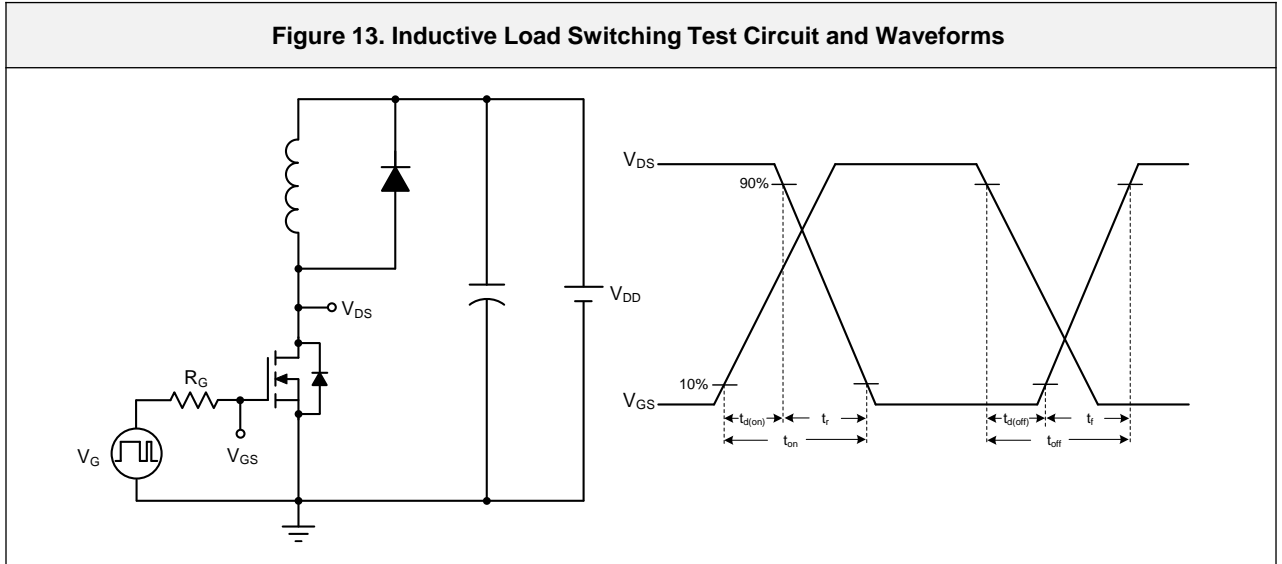

Figure 14. Unclamped Inductive Switching Test Circuit and Waveforms

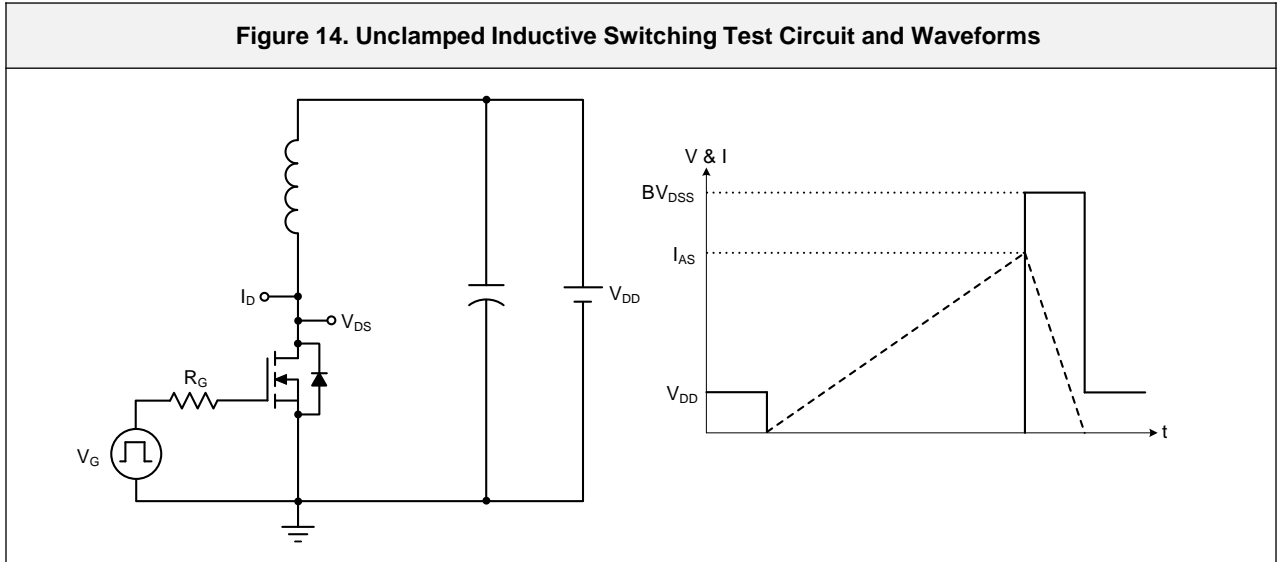
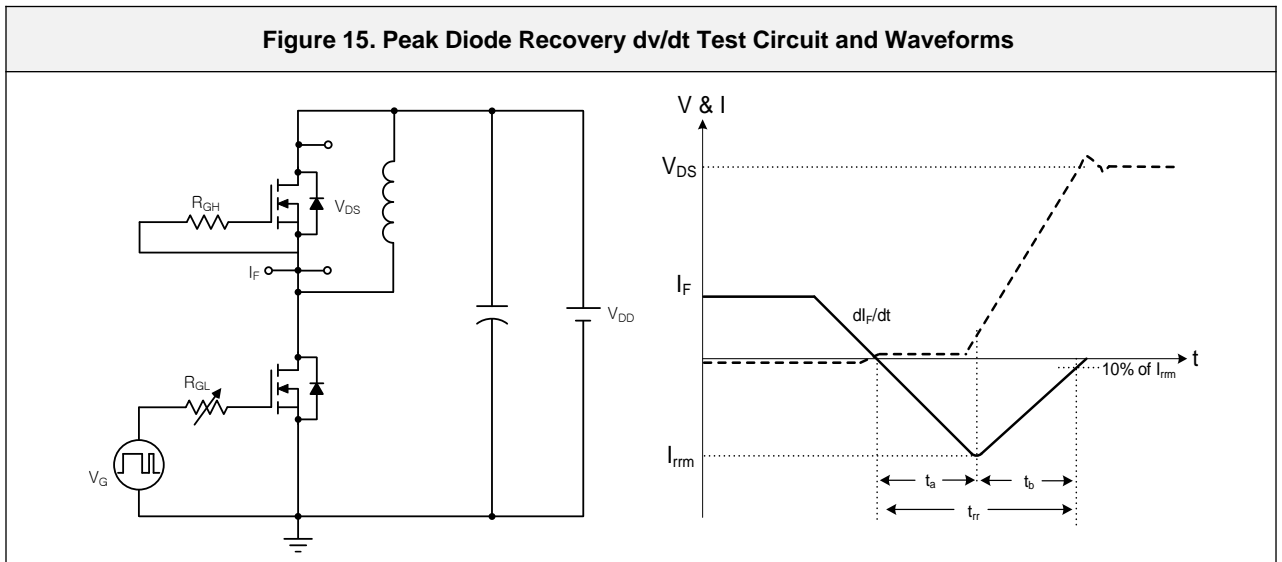
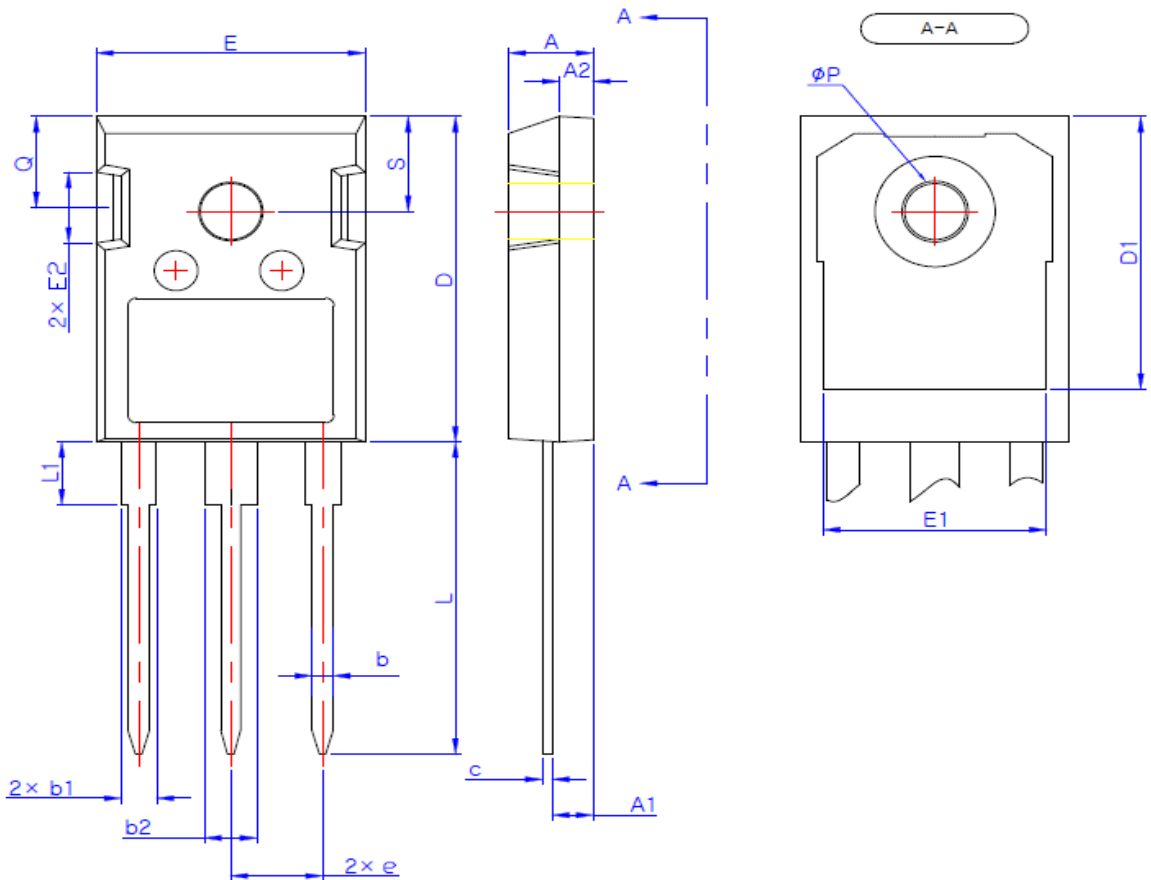

Figure 15. Peak Diode Recovery dv/dt Test Circuit and Waveforms



Package Outlines

TO-247



| SYMBOL | MIN | NOM | MAX |
|----------|----------|-------|-------|
| A | 4.80 | 5.00 | 5.20 |
| A1 | 2.29 | 2.42 | 2.54 |
| A2 | 1.90 | 2.00 | 2.10 |
| b | 1.10 | 1.20 | 1.30 |
| b1 | 1.91 | 2.06 | 2.20 |
| b2 | 2.92 | 3.06 | 3.20 |
| c | 0.50 | 0.60 | 0.70 |
| D | 20.80 | 21.07 | 21.34 |
| D1 | 17.43 | 17.63 | 17.83 |
| E | 15.75 | 15.94 | 16.13 |
| E1 | 13.06 | 13.26 | 13.46 |
| E2 | 4.32 | 4.58 | 4.83 |
| e | 5.45 BSC | | |
| L | 19.85 | 20.05 | 20.25 |
| L1 | 4.05 | 4.27 | 4.49 |
| ϕP | 3.55 | 3.60 | 3.65 |
| Q | 5.59 | 5.89 | 6.19 |
| S | 6.15 BSC | | |

* Dimensions in millimeters