

# HMW60N030UF7

## N-Channel eMOS UF7 Power MOSFET

600 V, 75 A, 30 mΩ

### Description

The 600V eMOS UF7 series has ultra-fast body diode performance using E7 technology. eMOS UF7 is Power Master Semiconductor's advanced fast recovery Super Junction MOSFET family by utilizing charge balance technology for excellent body diode performance, low on-resistance and reduced gate charge. It combines the benefits of a fast switching performance with ease of usage and robustness. Additionally, we offer low reverse recovery time (trr) and reverse recovery charge (Qrr) for the bridge structure topology, especially for resonant converters (LLC, PSFB, etc.).

### Applications

- Soft Switching Topologies
- Telecom and Server Power Supplies
- EV Charger and Industrial Power Supplies

### Features

$BV_{DSS} @ T_{J,max}$	$I_D$	$R_{DS(on),max}$	$Q_{g,typ}$
650 V	75 A	30 mΩ	195 nC

- Reduced Switching & Conduction Losses
- Fast Recovery Body-Diode
- Lower Gate Resistance
- 100% Avalanche Tested
- Pb-free and RoHS Compliant

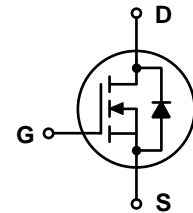
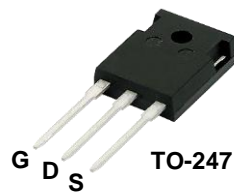

### Absolute Maximum Ratings ( $T_C = 25^\circ\text{C}$ unless otherwise noted)

Symbol	Parameter	Value	Unit
$V_{DSS}$	Drain to Source Voltage	600	V
$V_{GSS}$	Gate to Source Voltage	±30	V
$I_D$	Drain Current	Continuous ( $T_C = 25^\circ\text{C}$ )	75
		Continuous ( $T_C = 100^\circ\text{C}$ )	55
$I_{DM}$	Drain Current	Pulsed (Note1)	261
$E_{AS}$	Single Pulsed Avalanche Energy	(Note2)	655
$I_{AS}$	Avalanche Current	(Note2)	10.1
$E_{AR}$	Repetitive Avalanche Energy	(Note1)	5.68
dv/dt	MOSFET dv/dt	100	V/ns
	Peak Diode Recovery dv/dt	(Note3)	
$P_D$	Power Dissipation	( $T_C = 25^\circ\text{C}$ )	568
		Derate Above $25^\circ\text{C}$	4.55
$T_J, T_{STG}$	Operating and Storage Temperature Range	-55 to 150	$^\circ\text{C}$
$T_L$	Maximum Lead Temperature for Soldering, 1/8" from Case for 10 Seconds	260	$^\circ\text{C}$

### Thermal Characteristics

Symbol	Parameter	Value	Unit
$R_{\theta JC}$	Thermal Resistance, Junction to Case, Max.	0.22	$^\circ\text{C/W}$
$R_{\theta JA}$	Thermal Resistance, Junction to Ambient, Max.	40	

## Package Marking and Ordering Information

Part Number	Top Marking	Package	Packing Method	Quantity
HMW60N030UF7	HMW60N030UF7	TO-247	Tube	30 units

Electrical Characteristics ( $T_C = 25^\circ\text{C}$  unless otherwise noted)

Symbol	Parameter	Test Conditions	Min	Typ	Max	Unit
--------	-----------	-----------------	-----	-----	-----	------

## Off Characteristics

$BV_{DSS}$	Drain to Source Breakdown Voltage	$V_{GS} = 0\text{ V}, I_D = 1\text{ mA}$	600			V
		$V_{GS} = 0\text{ V}, I_D = 1\text{ mA}, T_J = 150^\circ\text{C}$	650			
$I_{DSS}$	Zero Gate Voltage Drain Current	$V_{DS} = 600\text{ V}, V_{GS} = 0\text{ V}$			10	$\mu\text{A}$
		$V_{DS} = 480\text{ V}, V_{GS} = 0\text{ V}, T_J = 125^\circ\text{C}$		85		
$I_{GSS}$	Gate-Source Leakage Current	$V_{GS} = \pm 30\text{ V}, V_{DS} = 0\text{ V}$			$\pm 100$	nA

## On Characteristics

$V_{GS(th)}$	Gate Threshold Voltage	$V_{GS} = V_{DS}, I_D = 5.0\text{ mA}$	3.0		5.0	V
$R_{DS(on)}$	Static Drain to Source On Resistance	$V_{GS} = 10\text{ V}, I_D = 37.5\text{ A}$		26	30	m $\Omega$

## Dynamic Characteristics

$C_{iss}$	Input Capacitance	$V_{DS} = 400\text{ V}, V_{GS} = 0\text{ V},$ $f = 250\text{ kHz}$		7941		pF
$C_{oss}$	Output Capacitance			204		pF
$C_{o(tr)}$	Time Related Output Capacitance	$V_{DS} = 0\text{ V to } 400\text{ V}, V_{GS} = 0\text{ V}$		2141		pF
$C_{o(er)}$	Energy Related Output Capacitance			316		pF
$Q_{g(tot)}$	Total Gate Charge at 10 V	$V_{DS} = 400\text{ V}, I_D = 37.5\text{ A},$ $V_{GS} = 10\text{ V}$		195		nC
$Q_{gs}$	Gate to Source Charge			50		nC
$Q_{gd}$	Gate to Drain "Miller" Charge			100		nC
$R_G$	Gate Resistance	$f = 1\text{ MHz}$		1		$\Omega$

## Switching Characteristics

$t_{d(on)}$	Turn-On Delay Time	$V_{DS} = 400\text{ V}, I_D = 37.5\text{ A},$ $V_{GS} = 10\text{ V}, R_G = 2.7\text{ }\Omega$ See Figure 13		35		ns
$t_r$	Turn-On Rise Time			16		ns
$t_{d(off)}$	Turn-Off Delay Time			114		ns
$t_f$	Turn-Off Fall Time			10		ns

## Source-Drain Diode Characteristics

$I_S$	Maximum Continuous Diode Forward Current			75	A
$I_{SM}$	Maximum Pulsed Diode Forward Current			261	A
$V_{SD}$	Diode Forward Voltage	$V_{GS} = 0\text{ V}, I_{SD} = 37.5\text{ A}$		1.2	V
$t_{rr}$	Reverse Recovery Time	$V_{DD} = 400\text{ V}, I_{SD} = 37.5\text{ A},$ $di_F/dt = 100\text{ A}/\mu\text{s}$		198	ns
$Q_{rr}$	Reverse Recovery Charge			1.8	$\mu\text{C}$

## ※Notes:

1. Repetitive rating: pulse-width limited by maximum junction temperature.
2.  $I_{AS} = 10.1\text{ A}, R_G = 25\text{ }\Omega$ , starting  $T_J = 25^\circ\text{C}$ .
3.  $I_{SD} \leq 37.5\text{ A}, di/dt \leq 100\text{ A}/\mu\text{s}, V_{DD} \leq 400\text{ V}$ , starting  $T_J = 25^\circ\text{C}$ .

Typical Performance Characteristics

Figure 1. On-Region Characteristics

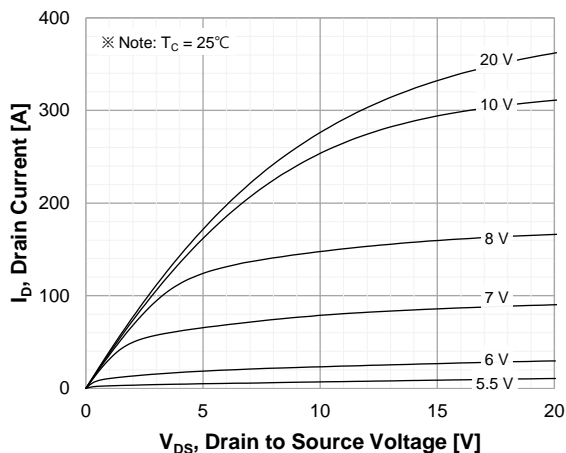

Figure 2. Transfer Characteristics

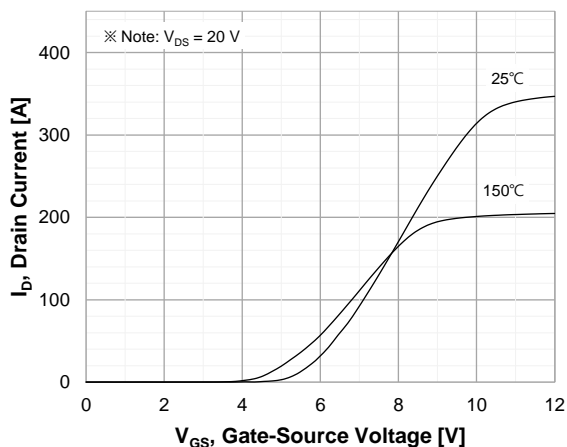

Figure 3. On-Resistance Characteristics vs. Drain Current and Gate Voltage

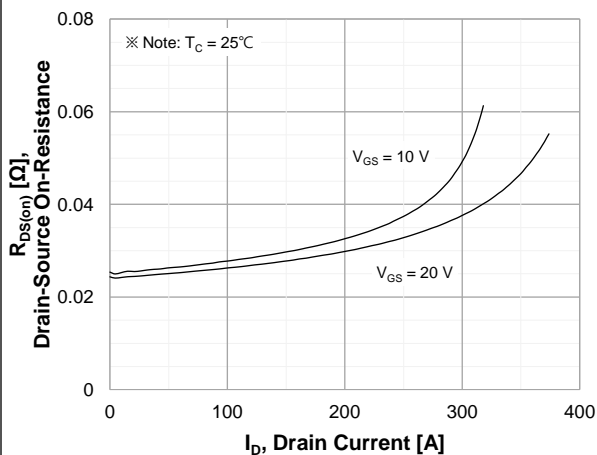

Figure 4. Diode Forward Voltage Characteristics vs. Source-Drain Current and Temperature

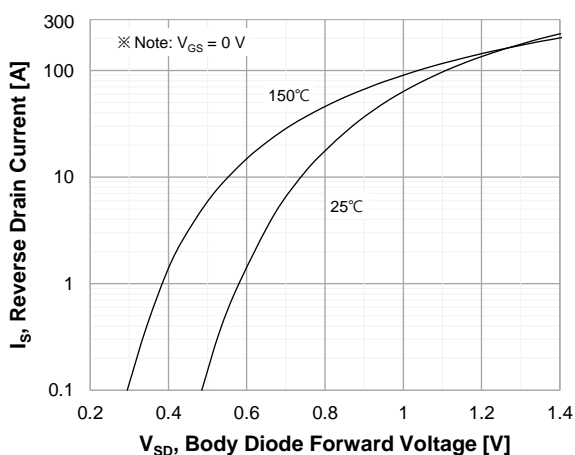

Figure 5. Capacitance Characteristics

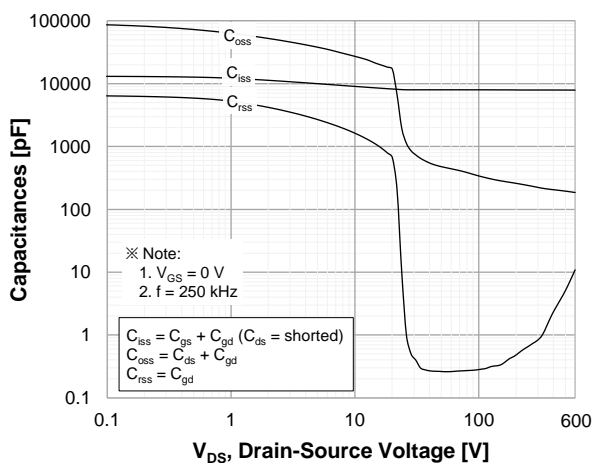
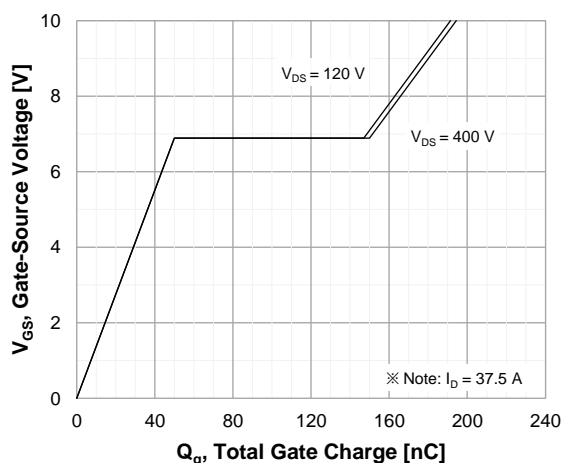

Figure 6. Gate Charge Characteristics



Typical Performance Characteristics

Figure 7. Breakdown Voltage Characteristics vs. Temperature

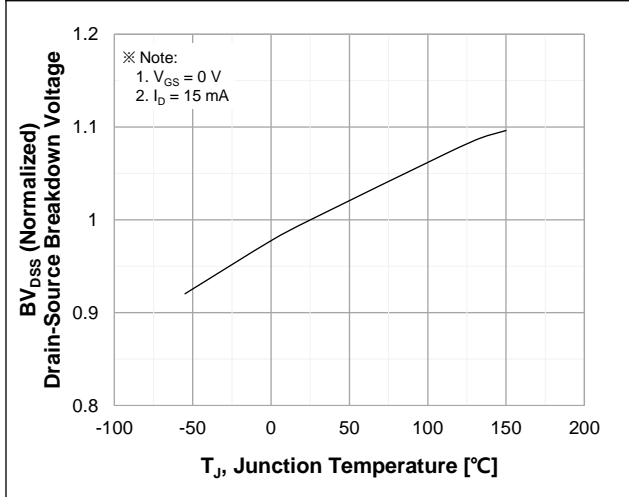

Figure 8. On-Resistance Characteristics vs. Temperature

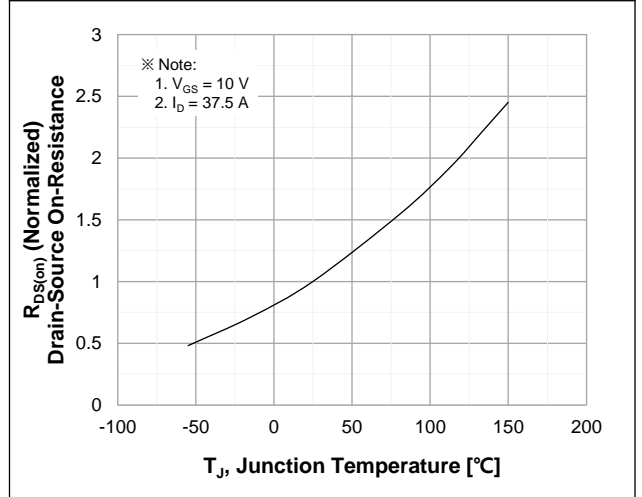

Figure 9. Maximum Safe Operating Area

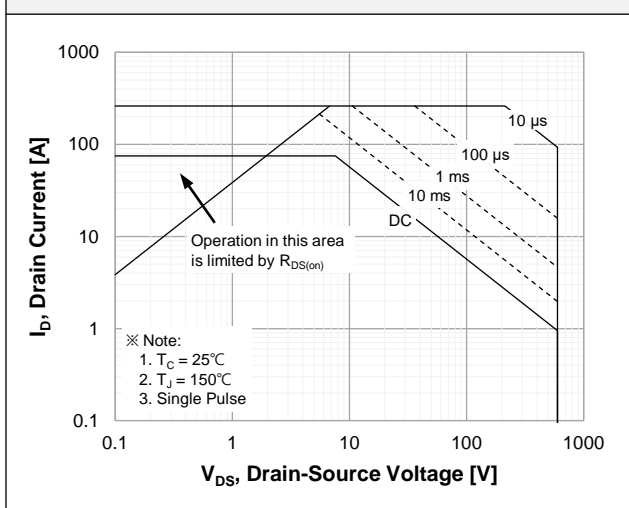

Figure 10. Maximum Drain Current vs. Case Temperature

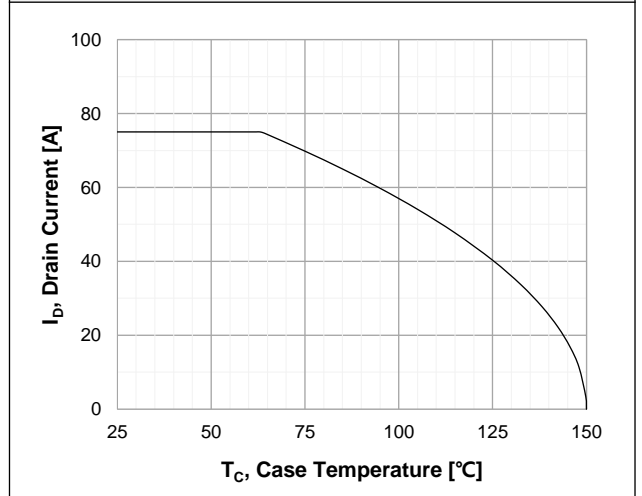

Figure 11. E\_oss vs. Drain to Source Voltage

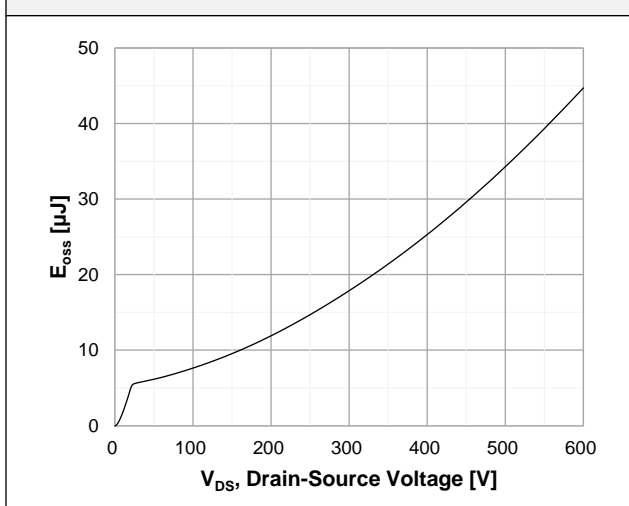
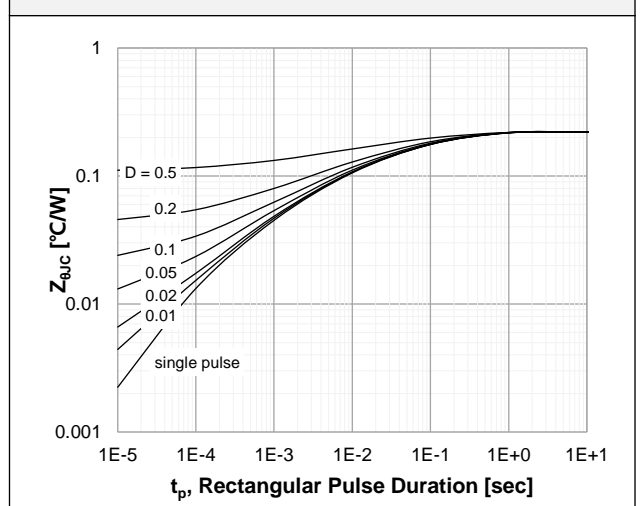

Figure 12. Transient Thermal Response Curve



Test Circuits

Figure 13. Inductive Load Switching Test Circuit and Waveforms

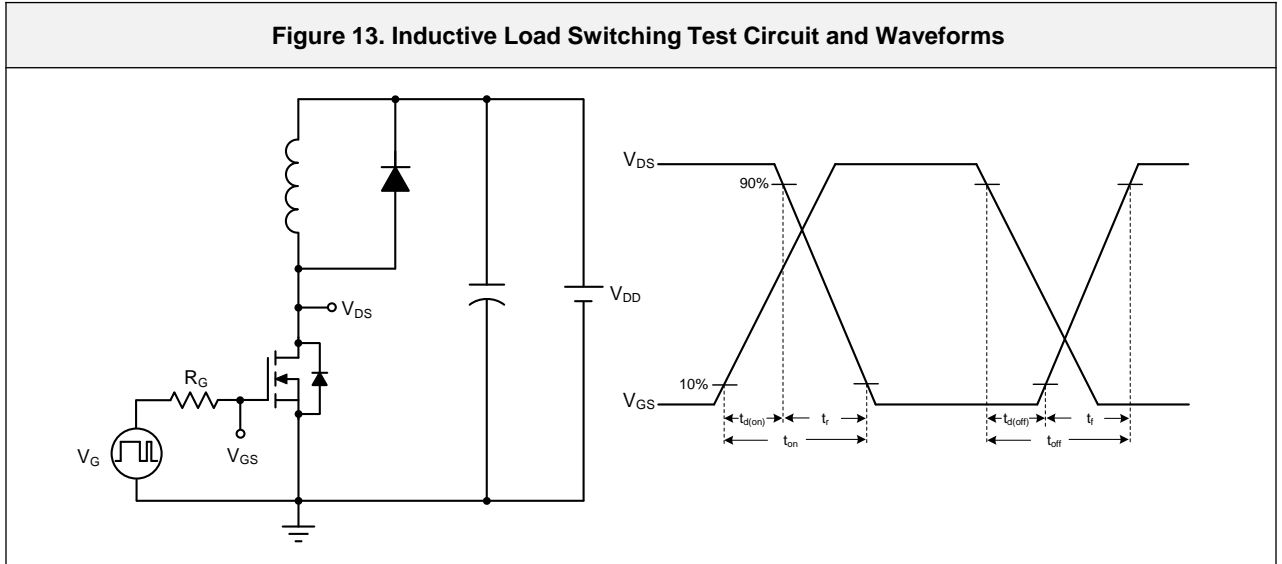

Figure 14. Unclamped Inductive Switching Test Circuit and Waveforms

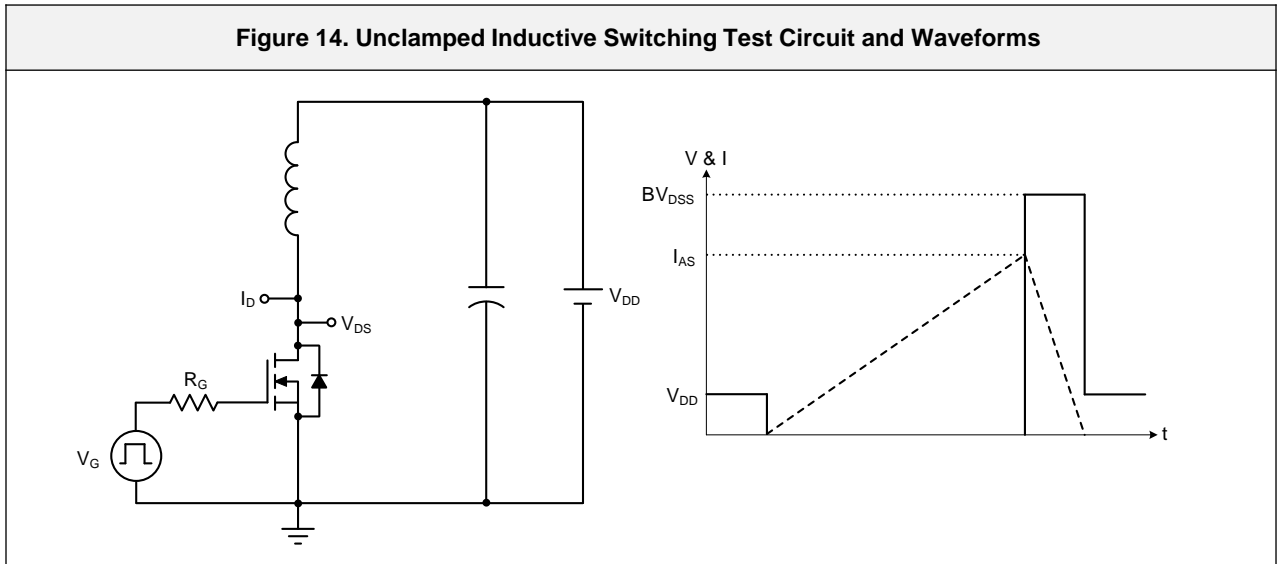
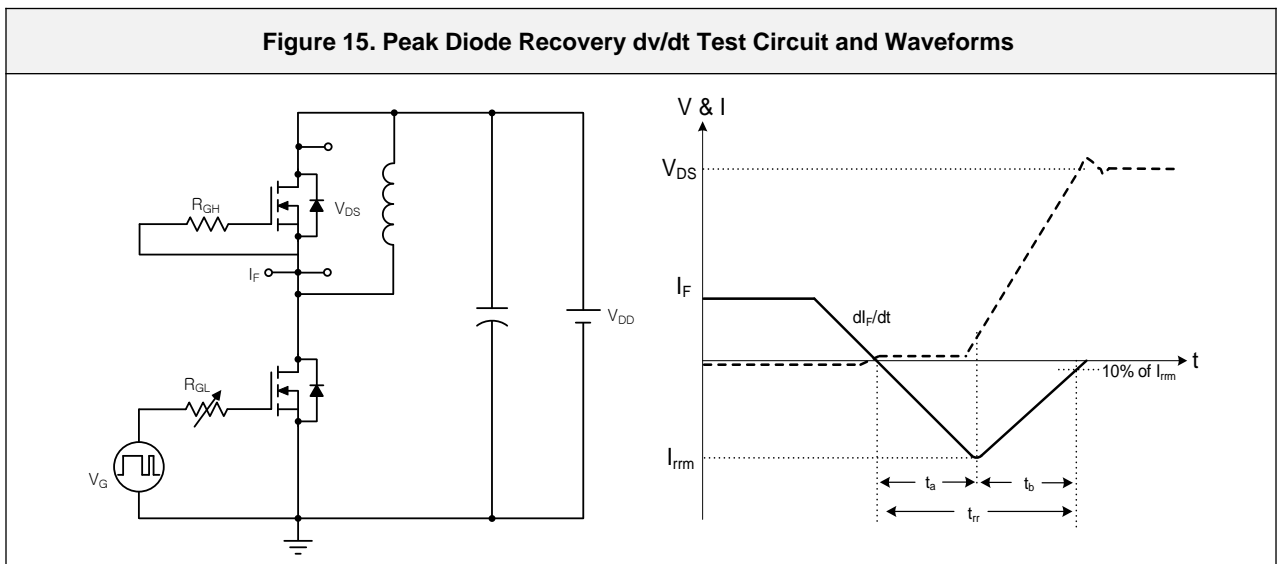
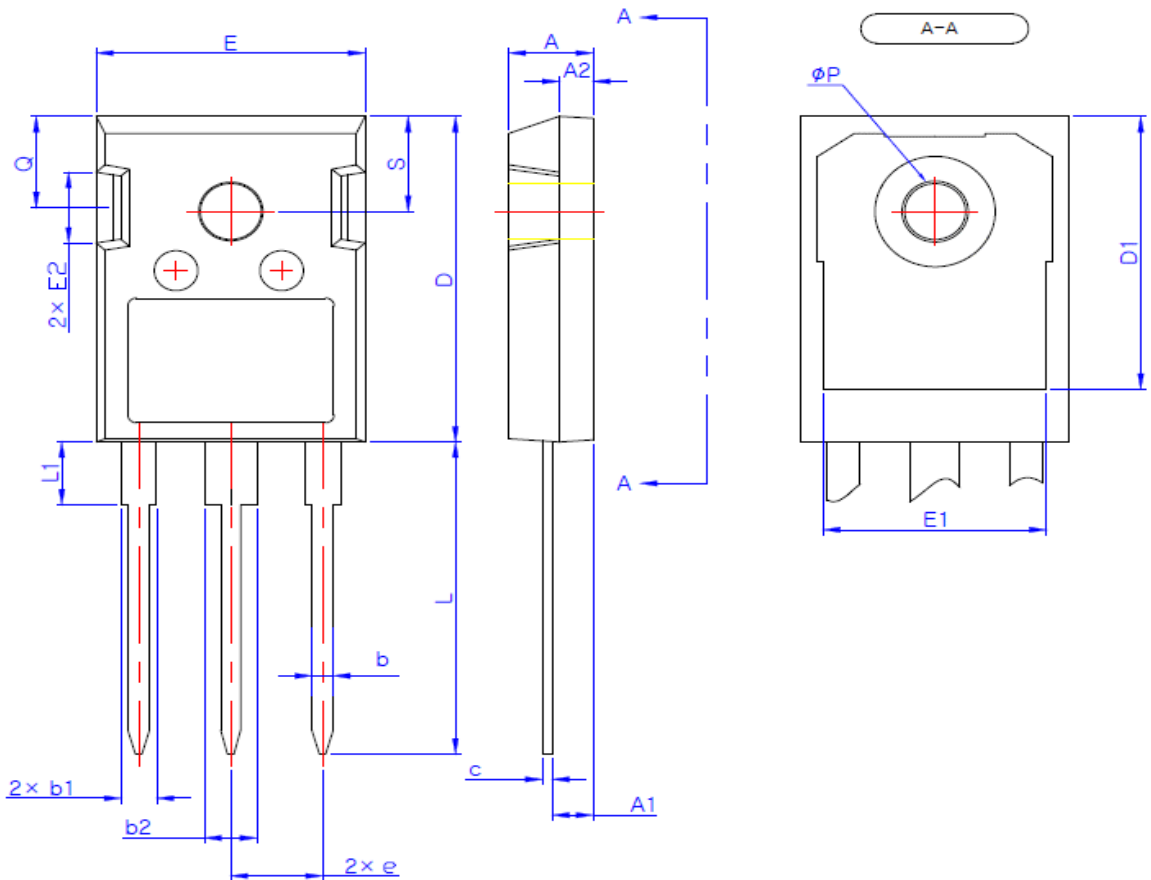

Figure 15. Peak Diode Recovery dv/dt Test Circuit and Waveforms



Package Outlines

TO-247



SYMBOL	MIN	NOM	MAX
A	4.80	5.00	5.20
A1	2.29	2.42	2.54
A2	1.90	2.00	2.10
b	1.10	1.20	1.30
b1	1.91	2.06	2.20
b2	2.92	3.06	3.20
c	0.50	0.60	0.70
D	20.80	21.07	21.34
D1	17.43	17.63	17.83
E	15.75	15.94	16.13
E1	13.06	13.26	13.46
E2	4.32	4.58	4.83
e	5.45 BSC		
L	19.85	20.05	20.25
L1	4.05	4.27	4.49
phi P	3.55	3.60	3.65
Q	5.59	5.89	6.19
S	6.15 BSC		

\* Dimensions in millimeters