

# HMT60N105E7

## N-Channel eMOS E7 Power MOSFET

600 V, 31 A, 105 mΩ

### Description

The 600V eMOS E7 is an advanced Power Master Semiconductor's Super Junction MOSFET family by utilizing charge balance technology for excellent low on-resistance and gate charge. This technology combines the benefits of a fast switching performance with ease of usage and robustness. Consequently, the eMOS E7 family is suitable for application requiring high power density and superior efficiency. TOLL Kelvin source configuration package offers excellent switching performance thanks to separated power and drive sources for high efficiency and high switching frequency applications.

### Applications

- PFC, Hard & Soft Switching Topologies
- Industrial & Consumer Power Supplies

### Features

$BV_{DSS} @ T_{J,max}$	$I_D$	$R_{DS(on),max}$	$Q_{g,typ}$
650 V	31 A	105 mΩ	52 nC

- Reduced Switching & Conduction Losses
- Lower Gate Resistance
- 100% Avalanche Tested
- Pb-free, Halogen Free, RoHS and MSL1 Compliant

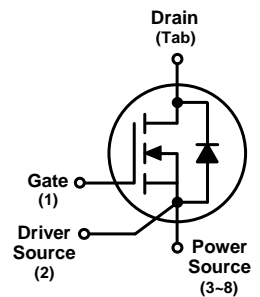
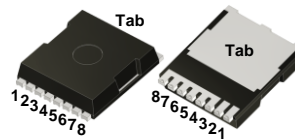

### Absolute Maximum Ratings ( $T_C = 25^\circ\text{C}$ unless otherwise noted)

Symbol	Parameter	Value	Unit
$V_{DSS}$	Drain to Source Voltage	600	V
$V_{GSS}$	Gate to Source Voltage	$\pm 30$	V
$I_D$	Drain Current	Continuous ( $T_C = 25^\circ\text{C}$ )	31
		Continuous ( $T_C = 100^\circ\text{C}$ )	19.6
$I_{DM}$	Drain Current	Pulsed (Note1)	93
$E_{AS}$	Single Pulsed Avalanche Energy	(Note2)	199
$I_{AS}$	Avalanche Current	(Note2)	5.6
$E_{AR}$	Repetitive Avalanche Energy	(Note1)	2.6
dv/dt	MOSFET dv/dt	100	V/ns
	Peak Diode Recovery dv/dt	(Note3)	
$P_D$	Power Dissipation	( $T_C = 25^\circ\text{C}$ )	260
		Derate Above $25^\circ\text{C}$	2.08
$T_J, T_{STG}$	Operating and Storage Temperature Range	-55 to 150	$^\circ\text{C}$
$T_L$	Maximum Lead Temperature for Soldering	260	$^\circ\text{C}$

### Thermal Characteristics

Symbol	Parameter	Value	Unit
$R_{\theta JC}$	Thermal Resistance, Junction to Case, Max.	0.48	$^\circ\text{C}/\text{W}$
$R_{\theta JA}$	Thermal Resistance, Junction to Ambient, Max. (Note4)	43	

## Package Marking and Ordering Information

Part Number	Top Marking	Package	Packing Method	Quantity
HMT60N105E7	HMT60N105E7	TOLL	Tape & Reel	1000 units

Electrical Characteristics ( $T_C = 25^\circ\text{C}$  unless otherwise noted)

Symbol	Parameter	Test Conditions	Min	Typ	Max	Unit
--------	-----------	-----------------	-----	-----	-----	------

## Off Characteristics

$BV_{DSS}$	Drain to Source Breakdown Voltage	$V_{GS} = 0\text{ V}, I_D = 1\text{ mA}$	600			V
		$V_{GS} = 0\text{ V}, I_D = 1\text{ mA}, T_J = 150^\circ\text{C}$	650			
$I_{DSS}$	Zero Gate Voltage Drain Current	$V_{DS} = 600\text{ V}, V_{GS} = 0\text{ V}$			1	$\mu\text{A}$
		$V_{DS} = 480\text{ V}, V_{GS} = 0\text{ V}, T_J = 125^\circ\text{C}$		2.1		
$I_{GSS}$	Gate-Source Leakage Current	$V_{GS} = \pm 30\text{ V}, V_{DS} = 0\text{ V}$			$\pm 100$	nA

## On Characteristics

$V_{GS(th)}$	Gate Threshold Voltage	$V_{GS} = V_{DS}, I_D = 2.1\text{ mA}$	2.5		4.5	V
$R_{DS(on)}$	Static Drain to Source On Resistance	$V_{GS} = 10\text{ V}, I_D = 15.3\text{ A}$		89	105	m $\Omega$

## Dynamic Characteristics

$C_{iss}$	Input Capacitance	$V_{DS} = 400\text{ V}, V_{GS} = 0\text{ V},$ $f = 250\text{ kHz}$		2270		pF
$C_{oss}$	Output Capacitance			58		pF
$C_{o(tr)}$	Time Related Output Capacitance	$V_{DS} = 0\text{ V to } 400\text{ V}, V_{GS} = 0\text{ V}$		670		pF
$C_{o(er)}$	Energy Related Output Capacitance			92		pF
$Q_{g(tot)}$	Total Gate Charge at 10 V	$V_{DS} = 400\text{ V}, I_D = 15.3\text{ A},$ $V_{GS} = 10\text{ V}$		52		nC
$Q_{gs}$	Gate to Source Charge			12.7		nC
$Q_{gd}$	Gate to Drain "Miller" Charge			22.4		nC
$R_G$	Gate Resistance	$f = 1\text{ MHz}$		0.9		$\Omega$

## Switching Characteristics

$t_{d(on)}$	Turn-On Delay Time	$V_{DS} = 400\text{ V}, I_D = 15.3\text{ A},$ $V_{GS} = 10\text{ V}, R_G = 10\ \Omega$ See Figure 13		18		ns
$t_r$	Turn-On Rise Time			9		ns
$t_{d(off)}$	Turn-Off Delay Time			83		ns
$t_f$	Turn-Off Fall Time			7		ns

## Source-Drain Diode Characteristics

$I_S$	Maximum Continuous Diode Forward Current			31		A
$I_{SM}$	Maximum Pulsed Diode Forward Current			93		A
$V_{SD}$	Diode Forward Voltage	$V_{GS} = 0\text{ V}, I_{SD} = 15.3\text{ A}$			1.2	V
$t_{rr}$	Reverse Recovery Time	$V_{DD} = 400\text{ V}, I_{SD} = 15.3\text{ A},$ $di_F/dt = 100\text{ A}/\mu\text{s}$		346		ns
$Q_{rr}$	Reverse Recovery Charge			5.1		$\mu\text{C}$

## ※Notes:

1. Repetitive rating: pulse-width limited by maximum junction temperature.
2.  $I_{AS} = 5.6\text{ A}, R_G = 25\ \Omega$ , starting  $T_J = 25^\circ\text{C}$ .
3.  $I_{SD} \leq 15.3\text{ A}, di/dt \leq 100\text{ A}/\mu\text{s}, V_{DD} \leq 400\text{ V}$ , starting  $T_J = 25^\circ\text{C}$ .
4. Device on 1.0 x 1.0 inch and 2-oz copper pad on 1.5 x 1.5 inch PCB FR4.

Typical Performance Characteristics

Figure 1. On-Region Characteristics

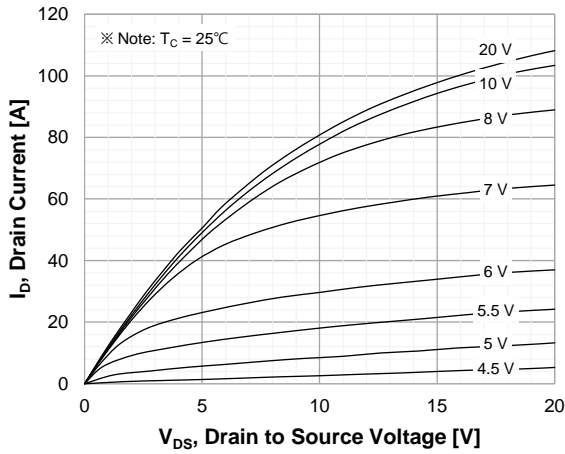

Figure 2. Transfer Characteristics

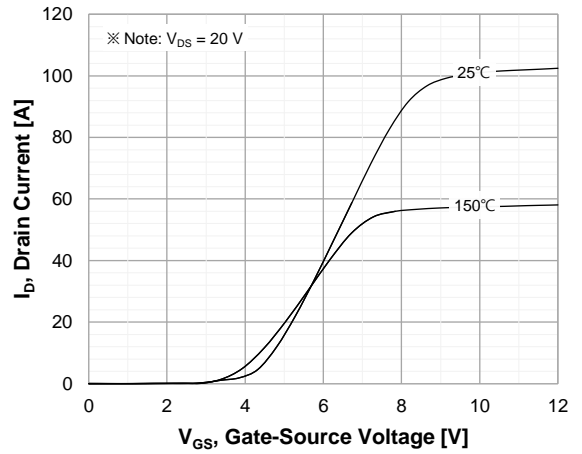

Figure 3. On-Resistance Characteristics vs. Drain Current and Gate Voltage

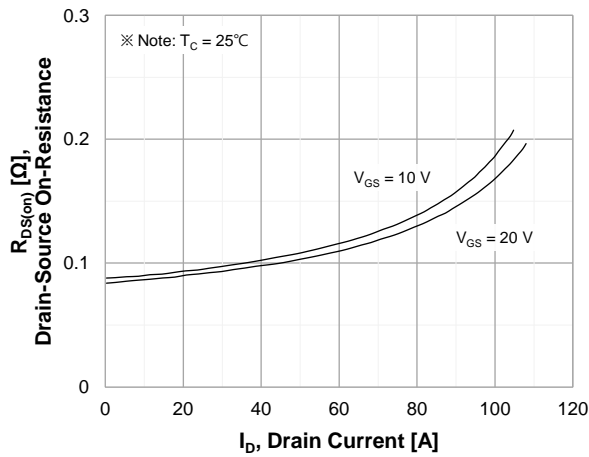

Figure 4. Diode Forward Voltage Characteristics vs. Source-Drain Current and Temperature

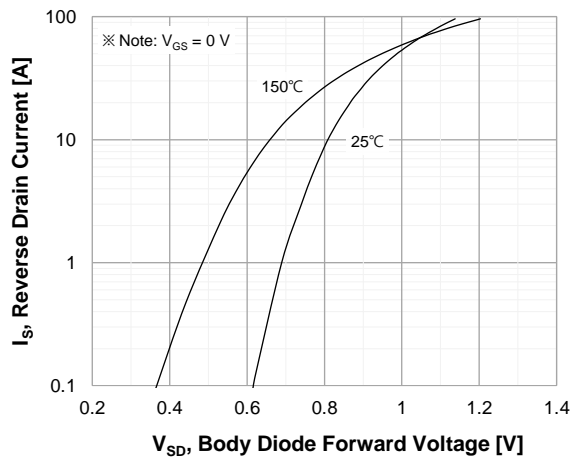

Figure 5. Capacitance Characteristics

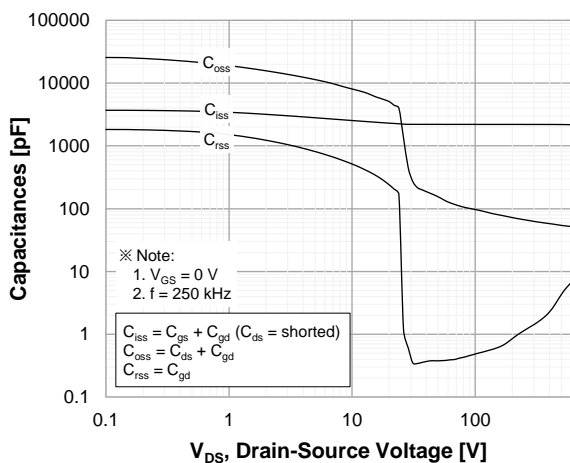
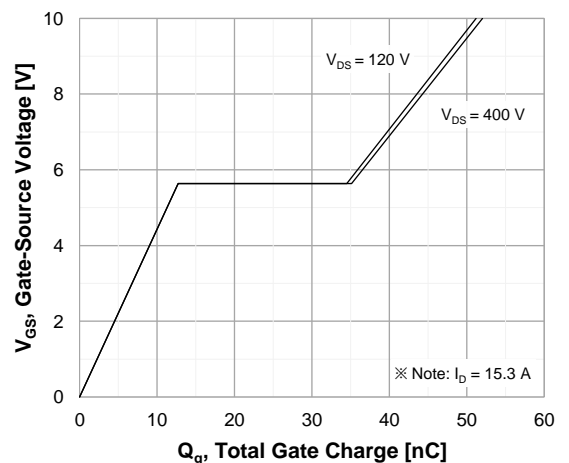

Figure 6. Gate Charge Characteristics



Typical Performance Characteristics

Figure 7. Breakdown Voltage Characteristics vs. Temperature

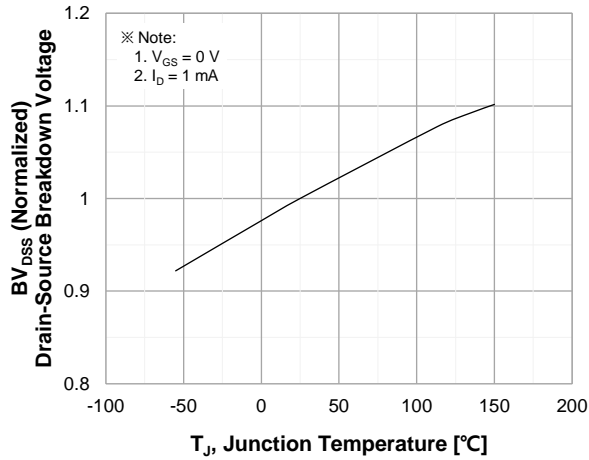

Figure 8. On-Resistance Characteristics vs. Temperature

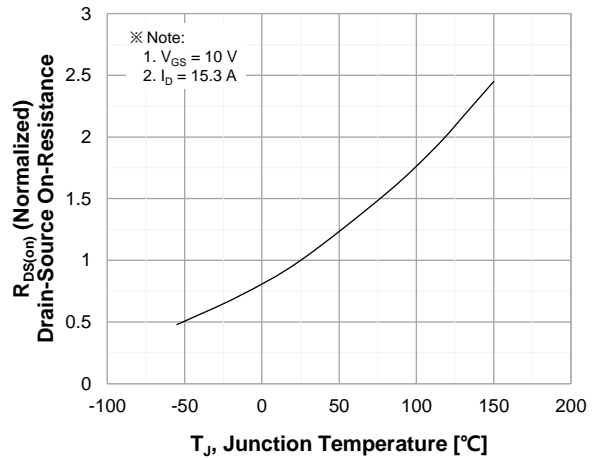

Figure 9. Maximum Safe Operating Area

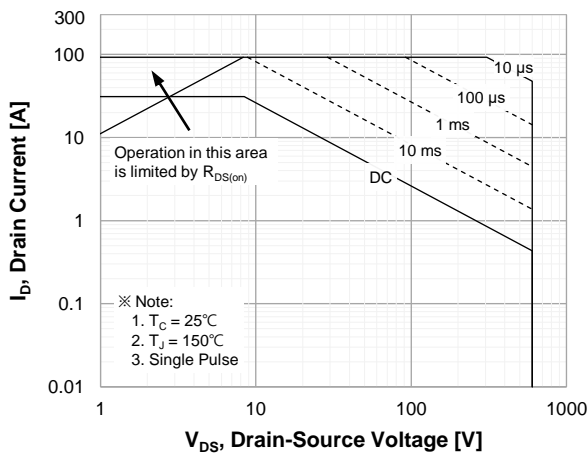

Figure 10. Maximum Drain Current vs. Case Temperature

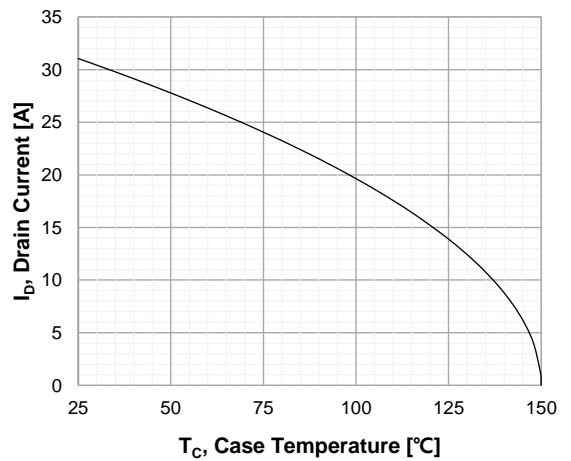

Figure 11. E\_oss vs. Drain to Source Voltage

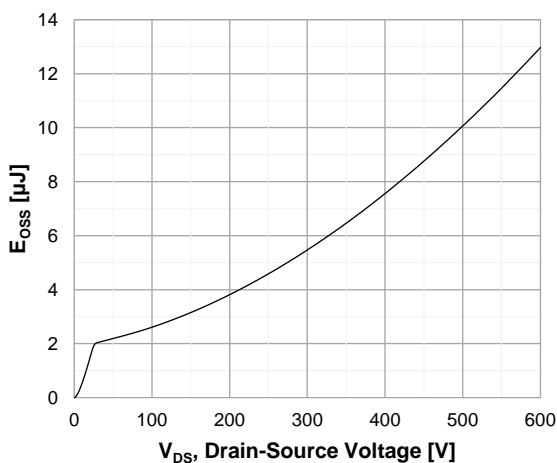
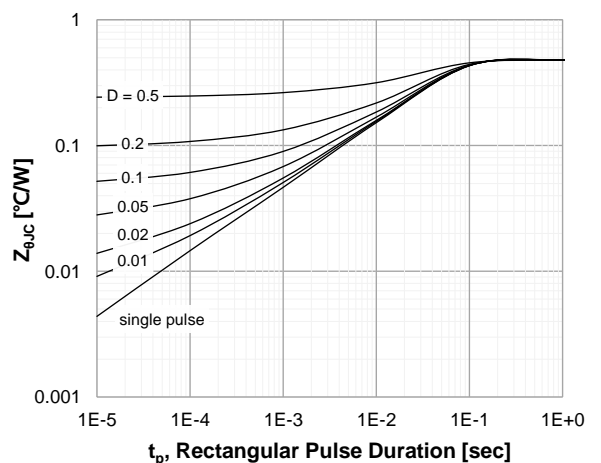

Figure 12. Transient Thermal Response Curve



Test Circuits

Figure 13. Inductive Load Switching Test Circuit and Waveforms

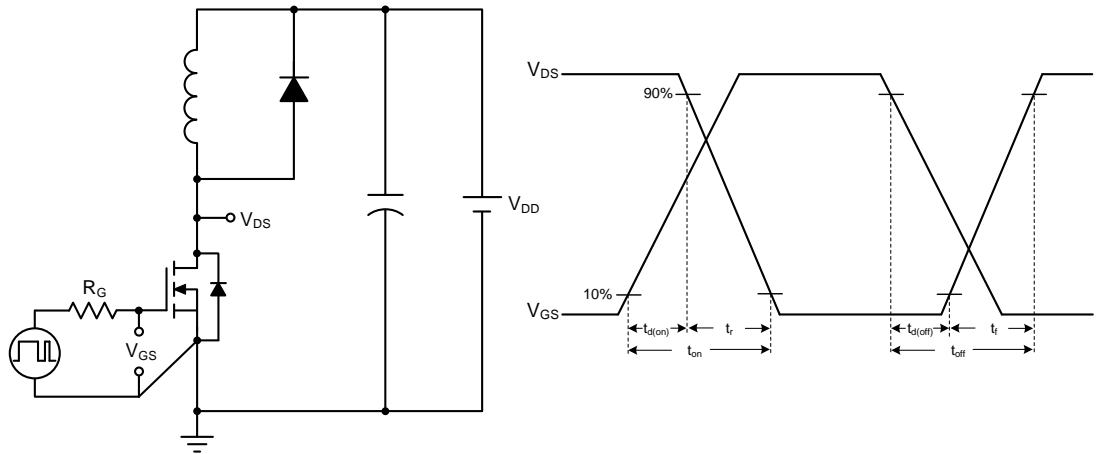

Figure 14. Unclamped Inductive Switching Test Circuit and Waveforms

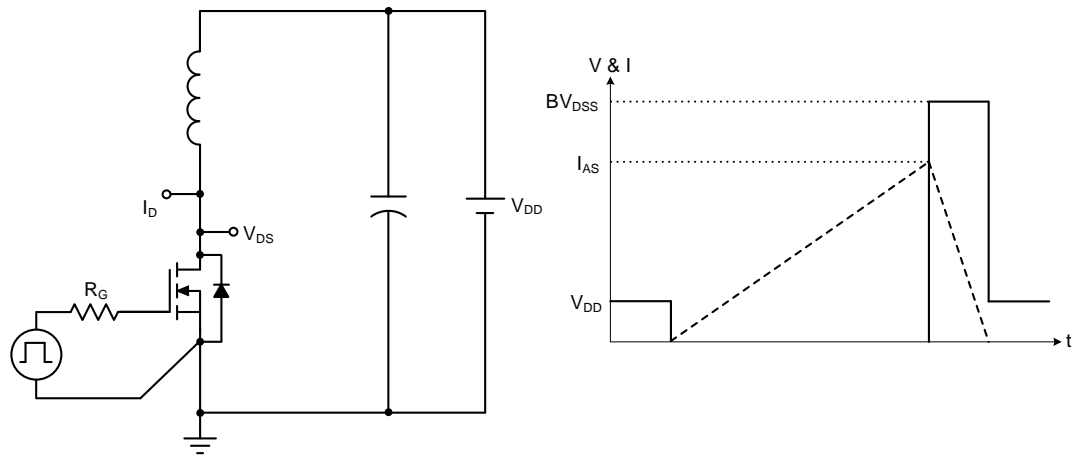
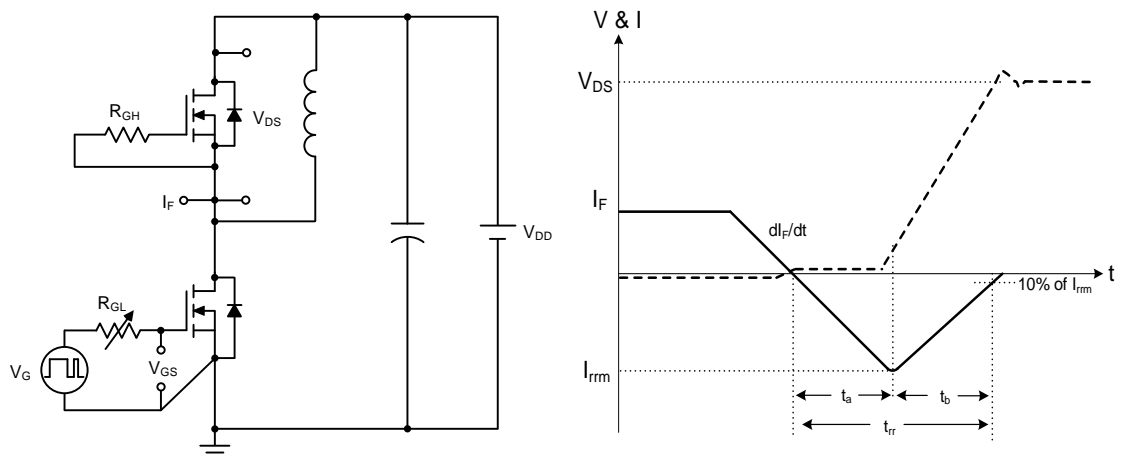
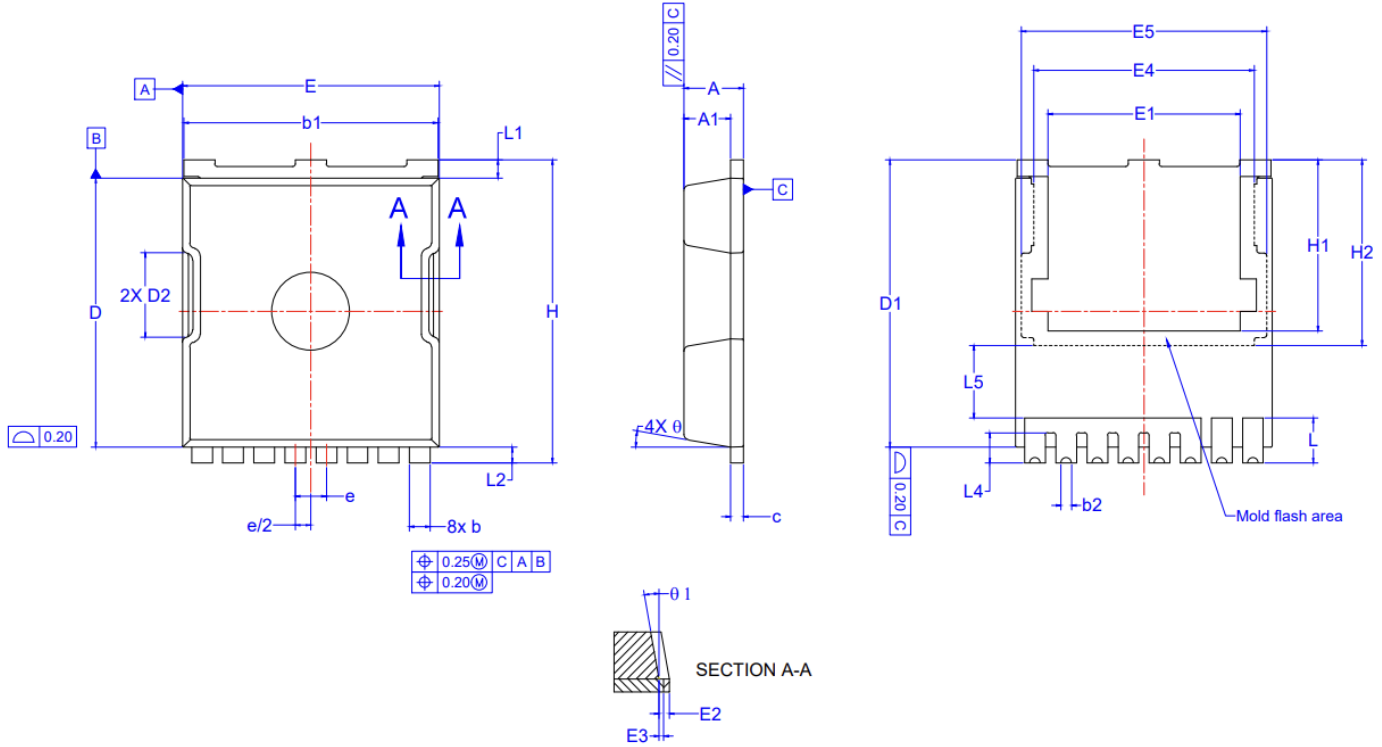

Figure 15. Peak Diode Recovery  $dv/dt$  Test Circuit and Waveforms



Package Outlines

TOLL



SYMBOL	MIN.	NOM.	MAX.
A	2.20	2.30	2.40
A1	1.70	1.80	1.90
b	0.70	0.80	0.90
b1	9.70	9.80	9.90
b2	0.36	0.41	0.51
c	0.40	0.50	0.60
D	10.28	10.38	10.48
D1	10.98	11.08	11.18
D2	3.30		
E	9.80	9.90	10.00
E1	7.32	7.42	7.52
E2	0.30	0.40	0.50
E3	0.15	0.18	0.21
E4	8.50		
E5	9.46		
e	1.20 BASIC		
H	11.58	11.68	11.78
H1	6.55	6.65	6.75
H2	7.05	7.15	7.25
L	1.63	1.73	1.83
L1	0.60	0.70	0.80
L2	0.50	0.60	0.70
L4	1.00	1.15	1.30
L5	2.70	2.80	2.90
N	8		
θ	10° REF.		
θ1	10° REF.		

\* Dimensions in millimeters